

- SPECIFICATIONS:**
1. 240VAC +10%/-15% SINGLE PHASE 50/60HZ
  2. 50°C MAXIMUM AMBIENT TEMPERATURE
  3. NEMA 1 CORROSION RESISTANT
  4. 6.00in [150mm] CLEARANCE TO BE KEPT ON BOTTOM OF POWER SUPPLY FOR COOLING FANS
  5. REQUIRED FREE SPACE NEEDED FOR COIL REMOVAL
  6. SEE THE FOLLOWING OUTLINE DRAWINGS FOR SEALING COILS:  
- UNIVERSAL COIL : G2126-11
  7. OPTIONS: BASE PACKAGE

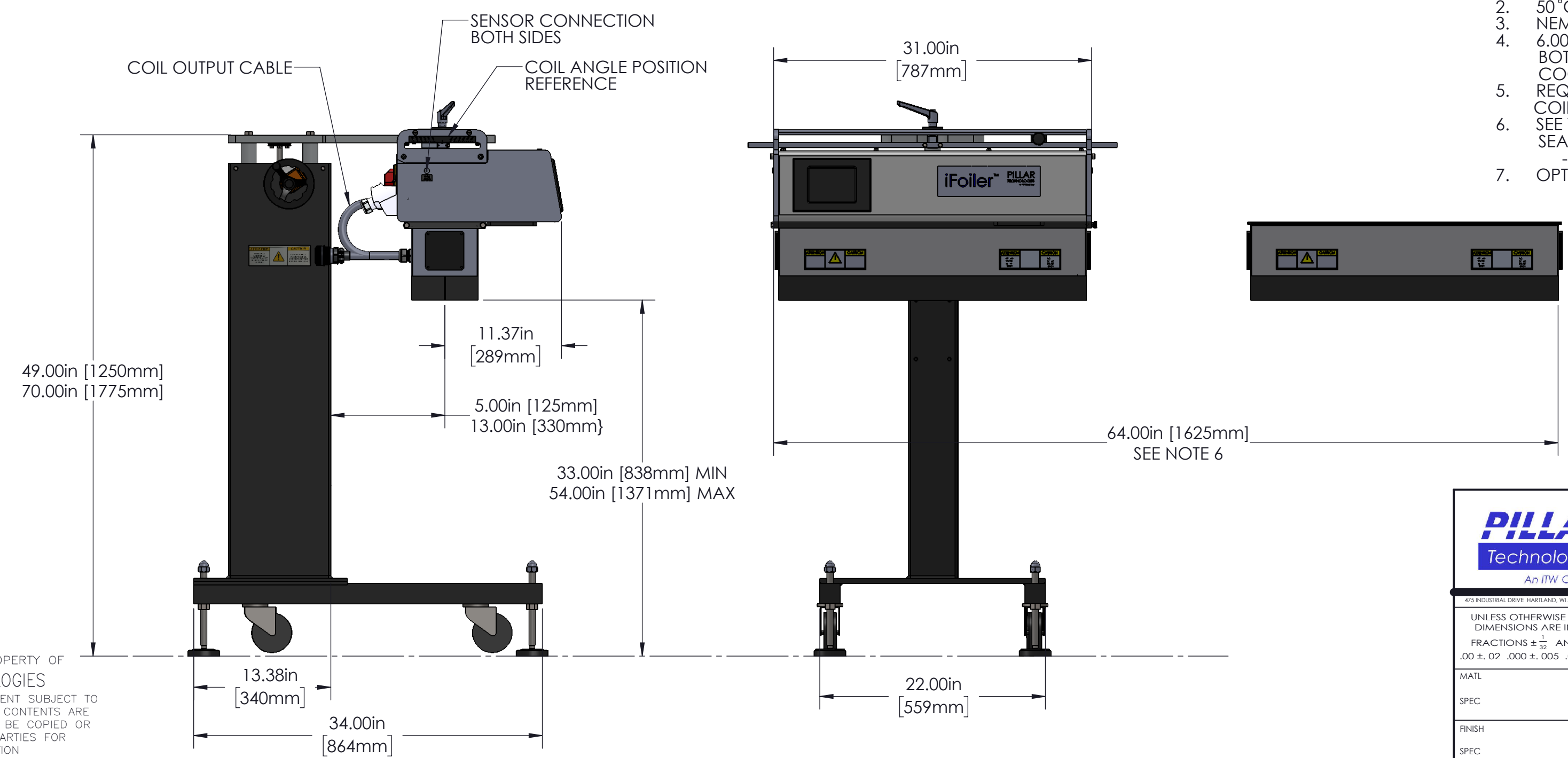

THIS PRINT IS THE PROPERTY OF  
PILLAR TECHNOLOGIES  
AND IS LOANED TO THE RECIPIENT SUBJECT TO  
RETURN UPON DEMAND. ITS CONTENTS ARE  
CONFIDENTIAL AND MUST NOT BE COPIED OR  
SUBMITTED TO OUTSIDE PARTIES FOR  
USE OR EXAMINATION

**PILLAR Technologies**  
An ITW Company  
425 INDUSTRIAL DRIVE HARTLAND, WI 53029 (262) 912-7200

UNLESS OTHERWISE SPECIFIED  
DIMENSIONS ARE IN INCHES  
FRACTIONS  $\pm \frac{1}{32}$  ANGLES  $\pm 1^\circ$   
.00  $\pm$  .02 .000  $\pm$  .005 .0000  $\pm$  .0005

MATL  
SPEC  
FINISH  
SPEC

REV	DESCRIPTION	ENG	DATE
REVISIONS			
REF DWGS			
FIRST USED ON			
DATE	DRAWN BY		
07/11/23	7/18/2023	EJU	
DESCRIPTION			
GENERAL OUTLINE			
IFOILER PLUS			
OPTIONS IN NOTES			
DWG NO			REV
G2126-1			
SCALE	1:10		SHEET 1 OF 1